

Asia
Alba
Nexum
Pro

VIBIA

Closer

Asia

Alba

Nexum

Pro

VIBIA

VIBIA

New Collections

Closer
06

Asia
28

Alba
48

Nexum
60

Pro
94

Closer

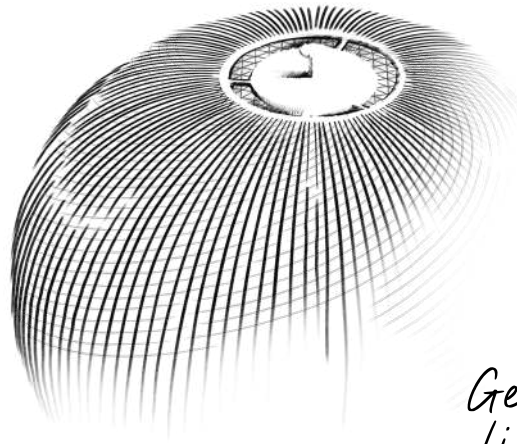

*Gentleness,
lightness*

Enveloped light

Intimate

Design by Ichiro Iwasaki.

A versatile and airy luminaire that transforms outdoor spaces into inviting retreats while blending seamlessly into interiors. Its inner light gently washes the knitted shade, revealing a warm translucent texture that enhances everyday moments.





“When outdoors, you want light to feel closer to you. A lamp with gentleness and lightness, comfortable when it is close to the body while in harmony with outdoor furniture that is meant for relaxation”.

Ichiro Iwasaki



The design process resulted in the creation of a slender, lightweight shade made from tubular woven knit, gradually expanding into a near-spherical shape. Despite its simplicity, the design was achieved through innovative techniques. This includes the use of a single, weather-resistant thread that holds its shape outdoors, as well as a precise molding process that clearly defines the knit's structure with both clarity and strength.

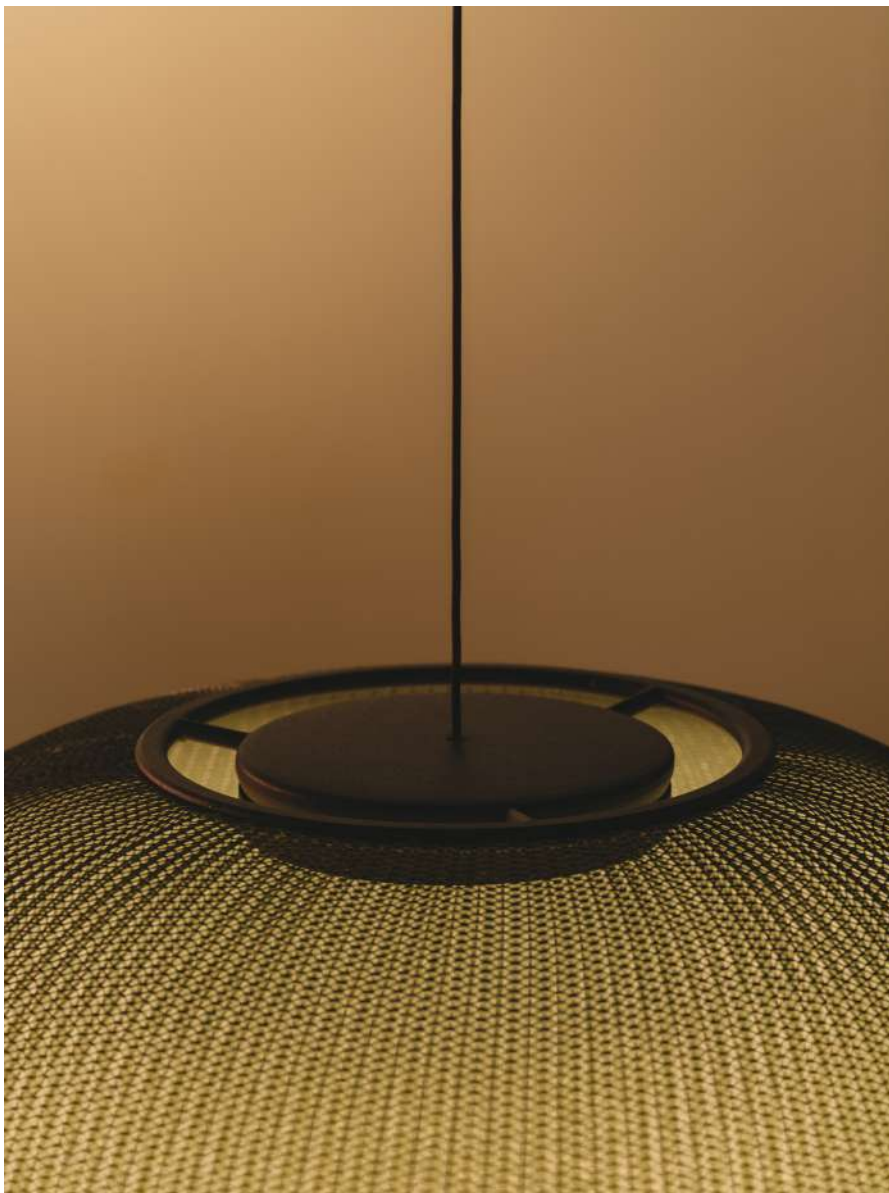



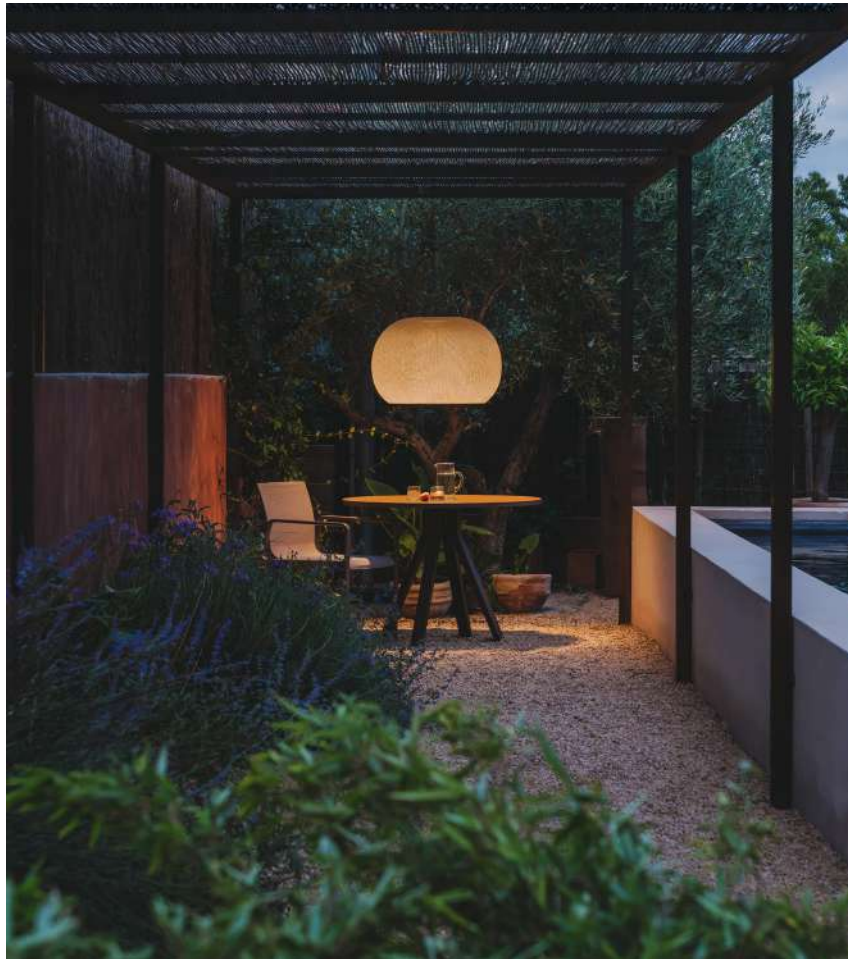



More than a luminaire, Closer follows daily moments as a glowing companion. Its wireless and surprisingly lightweight design makes it easy to bring along, adapting effortlessly to the rhythm of the day as it moves from place to place.







Rechargeable

Portable

The floor lamp charges wirelessly via induction and features a discreet switch button on top, offering three brightness levels.

1st Touch
Intensity 25%



2nd Touch
Intensity 50%



3rd Touch
Intensity 100%



Battery capacity:
20.800 mAh

Battery voltage:
3,7 V

Battery autonomy:
10 h at 100% Intensity
20 h at 50% Intensity
40 h at 25% Intensity













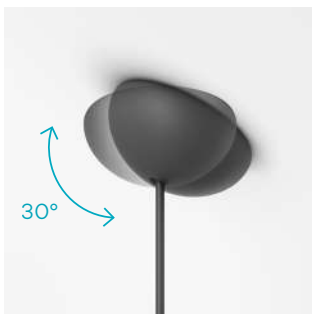

The rigid stem is designed to keep the luminaire precisely positioned above the surface, making it ideal for illuminating tables at these heights.

Available in two lengths, it allows the height to be adjusted according to the installation, ensuring stable, uniform light and optimal visual comfort.

Closer canopy features a versatile design that adapts precisely to both flat and sloped ceilings. Its discreet, refined form ensures a clean, visually-balanced installation while keeping the luminaire correctly oriented.

Outdoor - Pendant

CABLE

Height: max. 200 cm



Ø 68 cm
1700



Ø 56 cm
1702



Ø 49 cm
1704

RIGID STEM

Total height
106 cm / 150 cm

Ø 68 cm
1705



Ø 56 cm
1707



Ø 49 cm
1709

Fixed height of 106 cm / 150 cm

Outdoor - Floor & Table



Ø 68 cm
1710



Ø 56 cm
1712



Ø 49 cm
1714



- 25 Beige D1 (NCS S 4005-Y50R)
- 37 Terra Red (NCS S 4040-Y70R)
- 56 Green D1 (NCS S 7010-G30Y)

Body: Aluminum
 Shade: Polyester
 Diffuser: PMMA- Polymethylmethacrylate

LED Colour Temperature

2700 K
 CRI>90

Control

Analog: Push
 Digital: DALI-2
 Smart: Casambi

- IP44 Pendant
- IP65 Floor & Table

Electrical connection options



Remote

Built-in S

Surface, cable
 or rigid stem





Asia



Design by Antoni Arola.

The Asia collection combines refinement, simplicity, and warmth. It captures the serenity of traditional Oriental gabled rooftops and the delicacy of a molded glass, reimagined into an elegantly timeless luminaire.





“Asia is a house, an oriental house with a double-sloped roof that shields the light held within”.

Antoni Arola



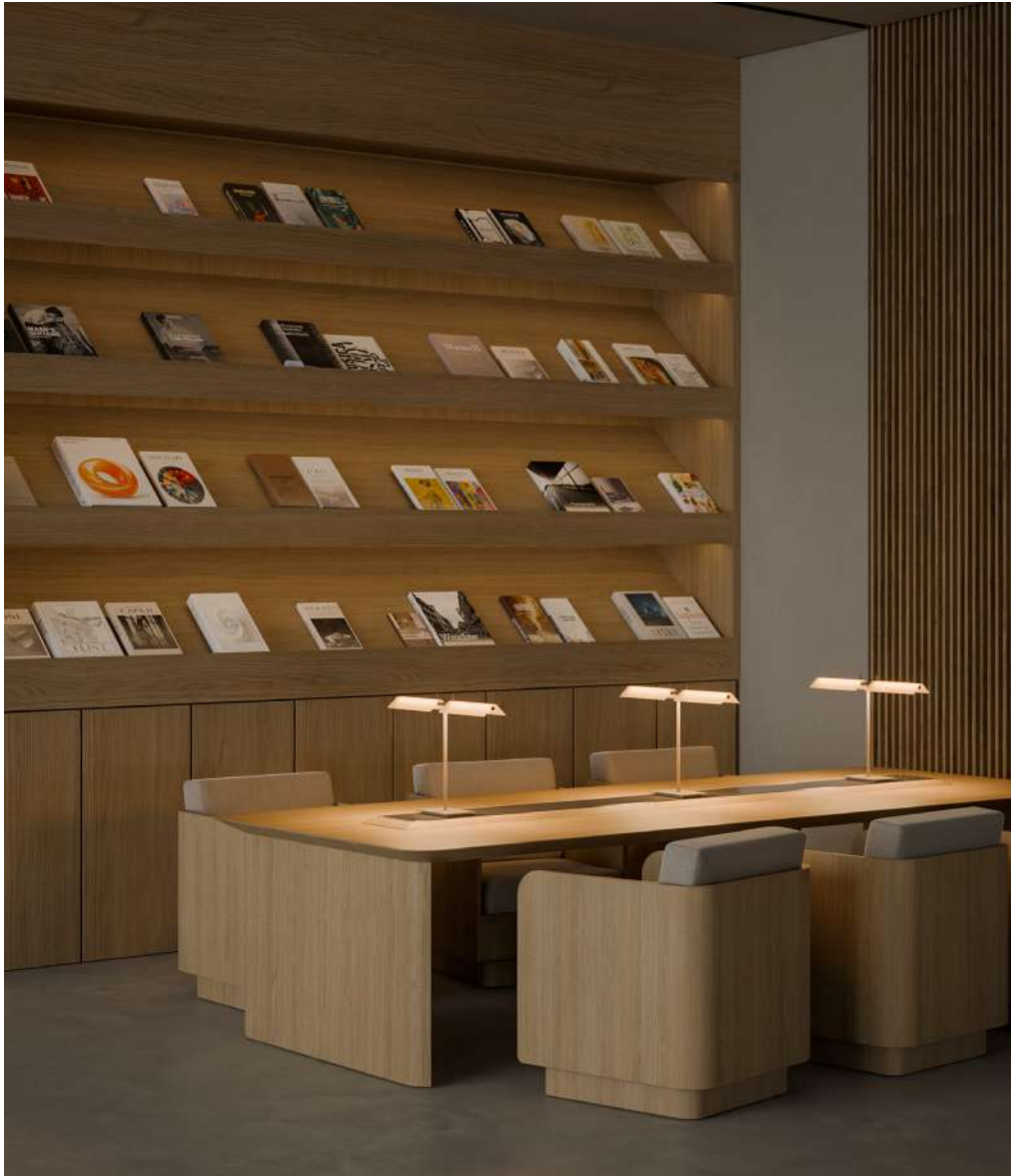





The floor and table versions share the same language and proportions, coexisting gracefully in the same space. Together, they engage in a quiet dialogue of harmonious forms and reflections, enhancing the possibilities of light and visual balance.





The adjustable diffuser transitions between direct and indirect light: when tilted, it casts a soft glow on nearby surfaces, while the lacquered glass diffuses the light, improving both visual comfort and the luminaires' aesthetic appeal.

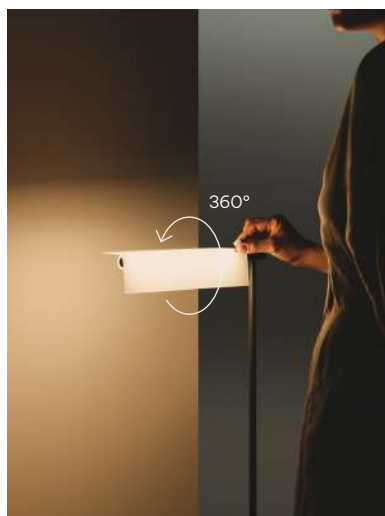











Asia captures the serene beauty of balance. Its lacquered glass softly filters light, reminiscent of delicate rice paper, diffusing a warm, tranquil glow. The suspension version offers both diffuse and directional light-intimate and focused when close to a surface, gently expansive as it ascends.

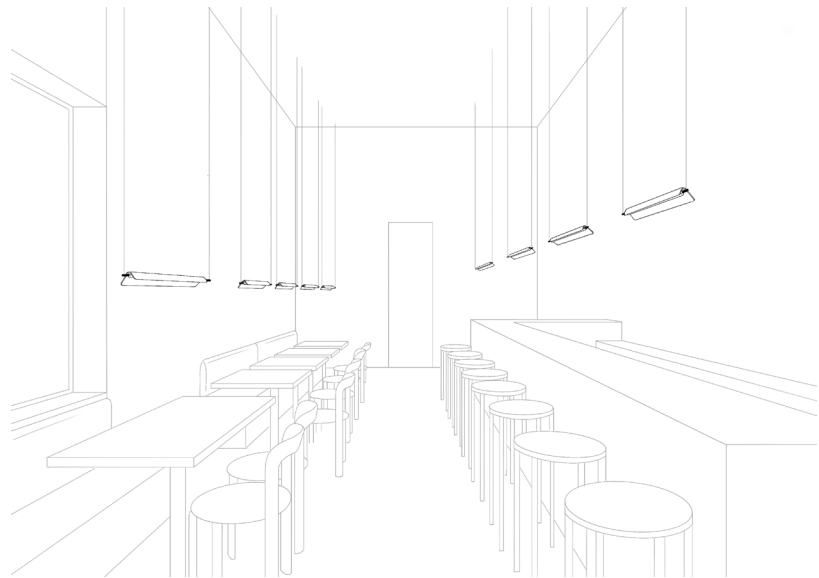



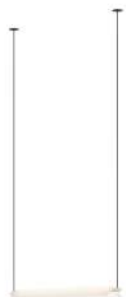

3625
45 cm

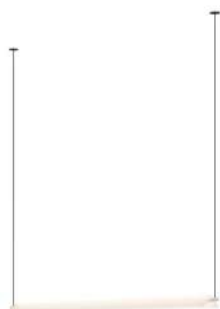

3627
85 cm



3630
125 cm



3635
30 x 38 cm



3637
55 x 38 cm



3640
30 x 112 cm

- 11 Black (NCS S 8500-N)
- 23 Warm White (NCS S 0502-Y50R)
- 25 Beige D1 (NCS S 4005-Y50R)

Shade: Lacquered glass
 Body: Aluminum / Stainless steel
 Diffuser: PC- Polycarbonate
 External diffuser: Ultra-clear quartz glass

LED Colour Temperature
 2700 K
 CRI>90

Control
 Analog: Push; 1-10V
 Digital: DALI-2
 Smart: Casambi

Electrical connection options



Remote
Micro

Built-in XS

Surface







Alba



Design by Palomba Serafini Associati.

Alba evokes dawn's first light with two softly balanced volumes, a glossy circular base and a luminous cylindrical diffuser, meeting in a subtle tangent to create a poetic, ethereal glow that blends form and illumination.





“An interplay of contacts and detachments, of tension and harmony, which we wanted to encapsulate in a name: Alba. It is that precise moment when the sun appears to touch the earth, either at dawn or sunset, before separating from it again”.

Palomba Serafini Associati





Alba moves with you effortlessly with a simple gesture. Light and portable, it brings cozy, subtle illumination to any space, whether on a table or adding a discreet glow, inviting you to carry it like a modern, lightweight candleholder.







1st Touch
Intensity 25%

2nd Touch
Intensity 50%

3rd Touch
Intensity 100%

Battery capacity:
5.000 mAh
Battery voltage:
3,7 V
Battery autonomy:
15 h at 100% Intensity
30 h at 50% Intensity
60 h at 25% Intensity

Alba integrates a USB-C charging system that ensures easy, efficient recharging. Designed for portability, it provides warm, adjustable light wherever it is needed, combining autonomy with elegant simplicity.

Portable

Rechargeable





A discreet switch concealed in the base allows intuitive control of Alba's three brightness levels. A simple gesture is enough to adjust the light intensity, ensuring visual calm and precise, comfortable control.

Alba is available in a selection of earthy hues from the Vibia palette, including beige, terracotta, and green, to complement its glossy surface and cylindrical light. This creates a subtle and sophisticated collection that evokes nature and brings harmony to any setting.



Ø 10 x 26 cm

3780

- 24 Beige M1 (NCS S 2005-Y50R)
- 38 Terra Dark (NCS S 5040-Y70R)
- 56 Green D1 (NCS S 7010-G30Y)

Diffuser: PMMA- Polymethylmethacrylate
Body: Aluminum

LED Colour Temperature

2700 K
CRI>90

Control

Analog: Push







Nexum



Design by Arik Levy.

Nexum reinterprets the chandelier with intertwining metal profiles, creating a balanced, three-dimensional light that fuses geometry and character into a striking statement.



Square

The Square versions offer a more sculptural and concentric interpretation of light. It can appear as a single piece or in dual compositions, with one luminaire nested within another to create depth and visual dynamism. This configuration establishes light hierarchies that transform the space into a graphic, enveloping and perfectly balanced structure.

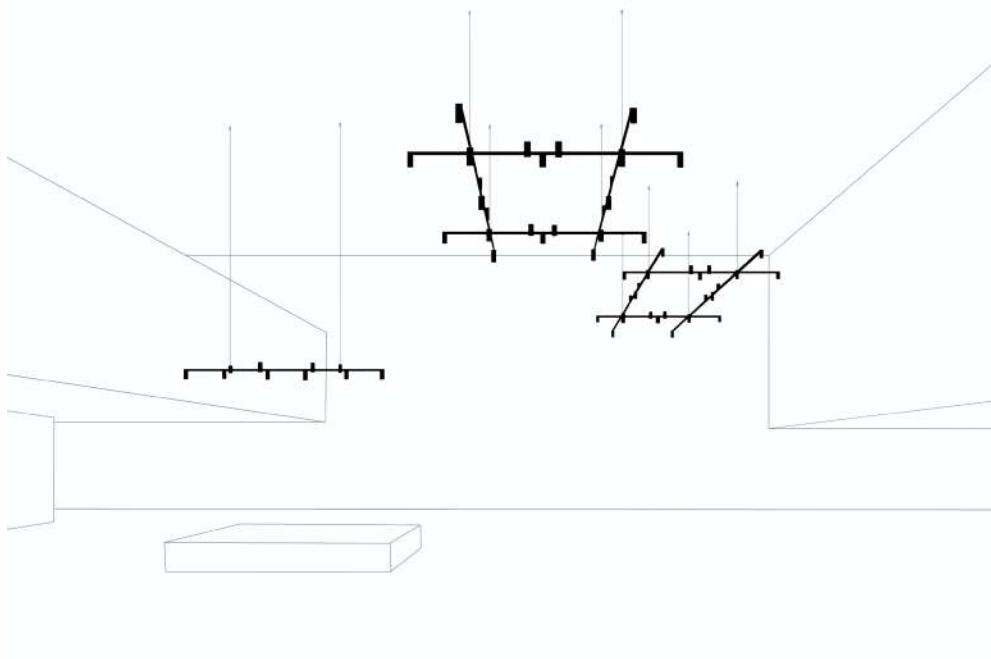

The elevated LED diffusers distribute light evenly without glare, blending spotlight precision with soft, tranquil illumination for a spacious, balanced ambiance.

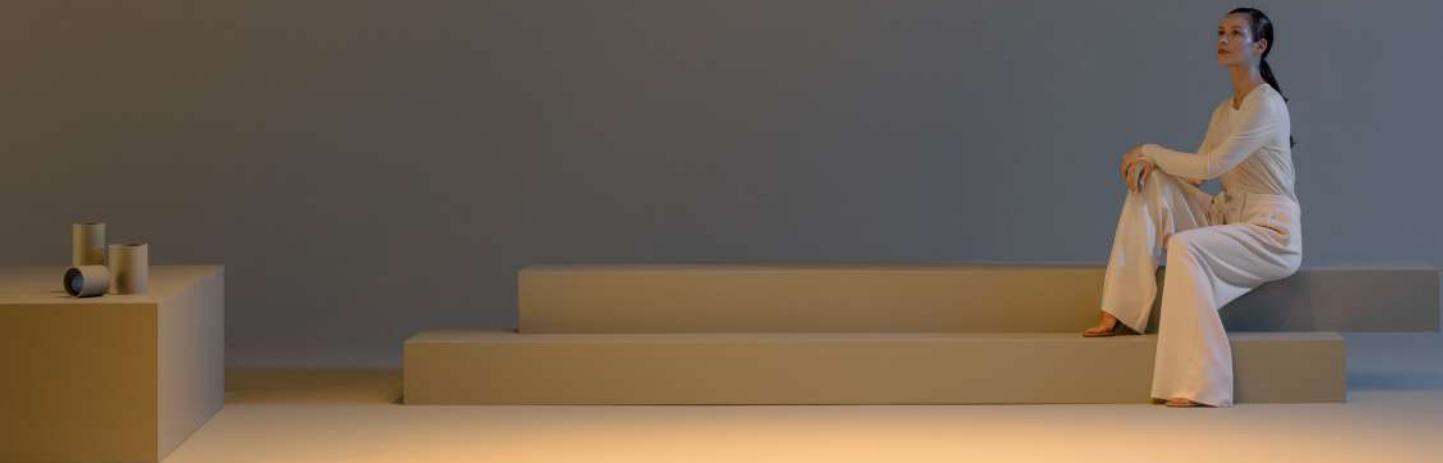



This system redefines modularity, offering the ability to grow and evolve in both horizontal and vertical planes. From delicate linear compositions to monumental chandeliers, Nexum expands with supreme elegance and finesse.

When architecture leads, light follows with precision. Nexum combines indirect illumination with controlled downward light, integrating seamlessly into the space to support both atmosphere and visual clarity.

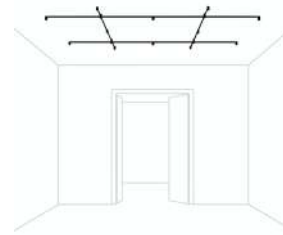
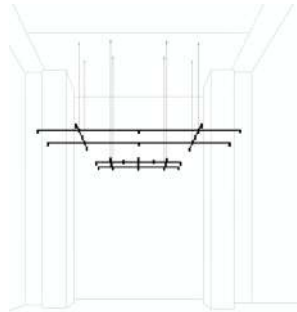
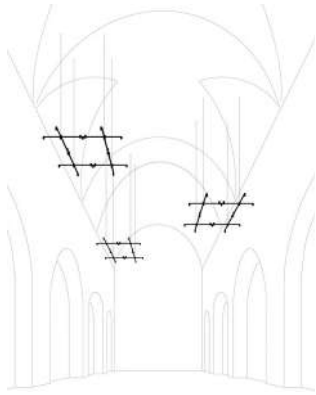

In an era where architecture demands adaptability, Nexum becomes an integral part of space rather than an object within it. When attached to the ceiling at zero distance, it delivers powerful illumination while remaining visually unobtrusive, leaving the living environment open, pure, and uninterrupted.



Rectangular

The Rectangular Nexum version projects a uniform, orderly light that defines the space with clarity. Its structure aligns seamlessly with the architecture, creating compositions of continuous lines and serene proportions. Ideal for tables, meeting areas, and transitional spaces, it combines technical precision with visual elegance, ensuring comfort and balance from above.



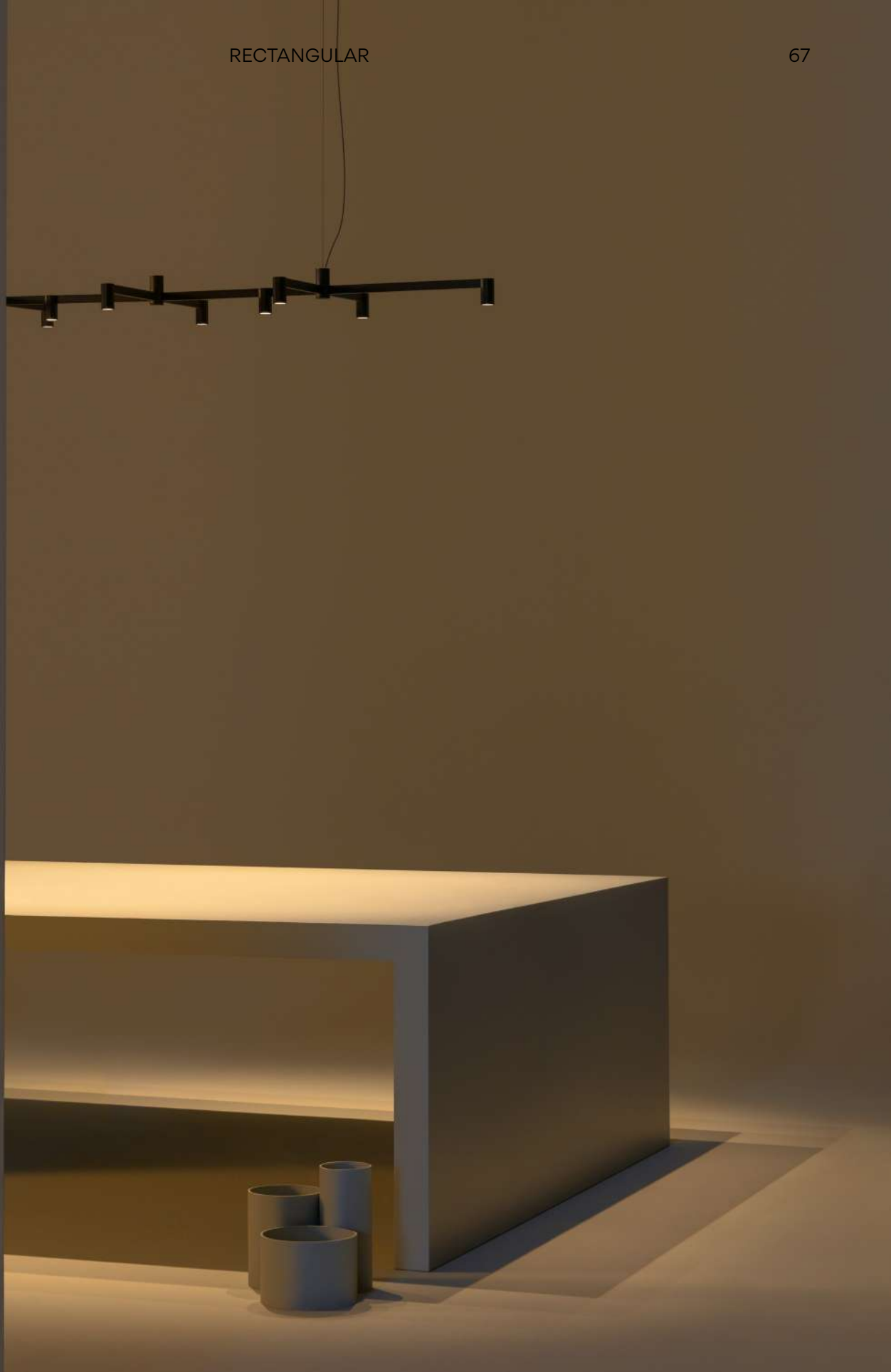

“With Nexum, light goes beyond illumination; it becomes a harmonious experience of form, function, and fluidity”.

Arik Levy

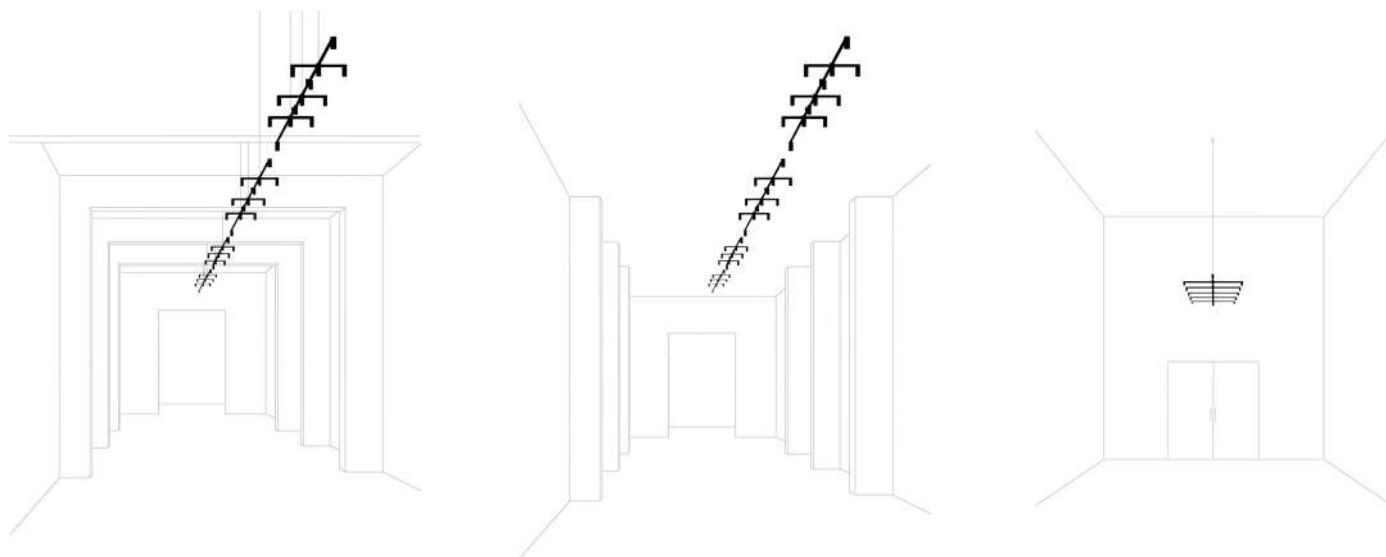

The Rectangular Nexum system provides balanced general lighting for complex transitional spaces. Its modular composition reflects and enhances the architectural rhythm of the environment.



Lineal

The Lineal Nexum version traces a clean, orderly line of light that follows the geometry of the architecture. Ideal for counters, long tables, kitchen islands, corridors or elongated spaces, its parallel arrangement ensures uniform illumination and a clear visual field, projecting light from a higher position with absolute visual comfort.







Its distinctive structure enables simultaneous uplighting and downlighting, creating a luminous volume that enhances the atmosphere with depth and presence.



With Nexum Lineal, large-scale spaces can be illuminated through a modular approach. In open, expansive environments, light remains precise and restrained, accompanying the architecture without competing with it.

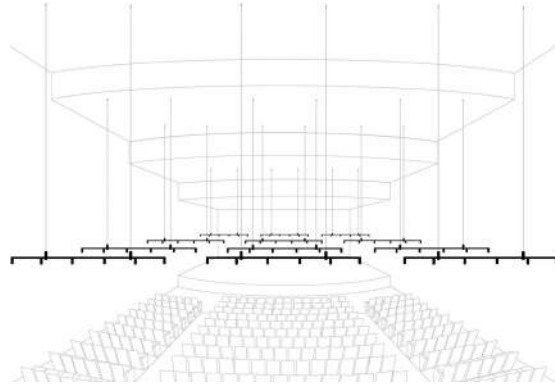

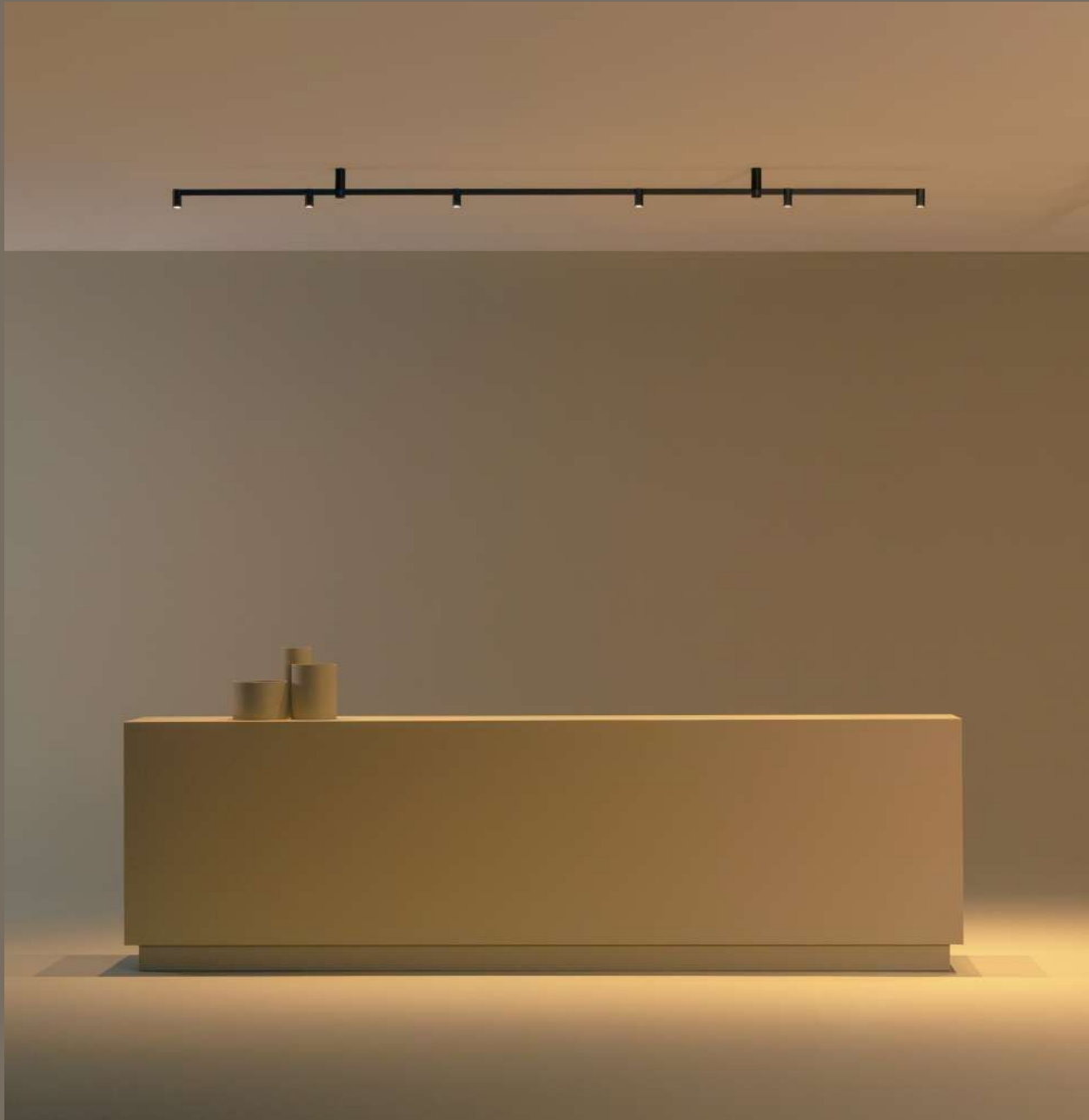

Volumetric

The Volumetric Nexum version represents the most expansive expression of the system. Available in small, medium and large formats, it adapts its presence to the proportions of each space, from contained compositions to striking visual statements. Its three-dimensional structure multiplies light in multiple directions, creating a sense of depth and lightness that redefines the traditional chandelier with a contemporary, architectural aesthetic.





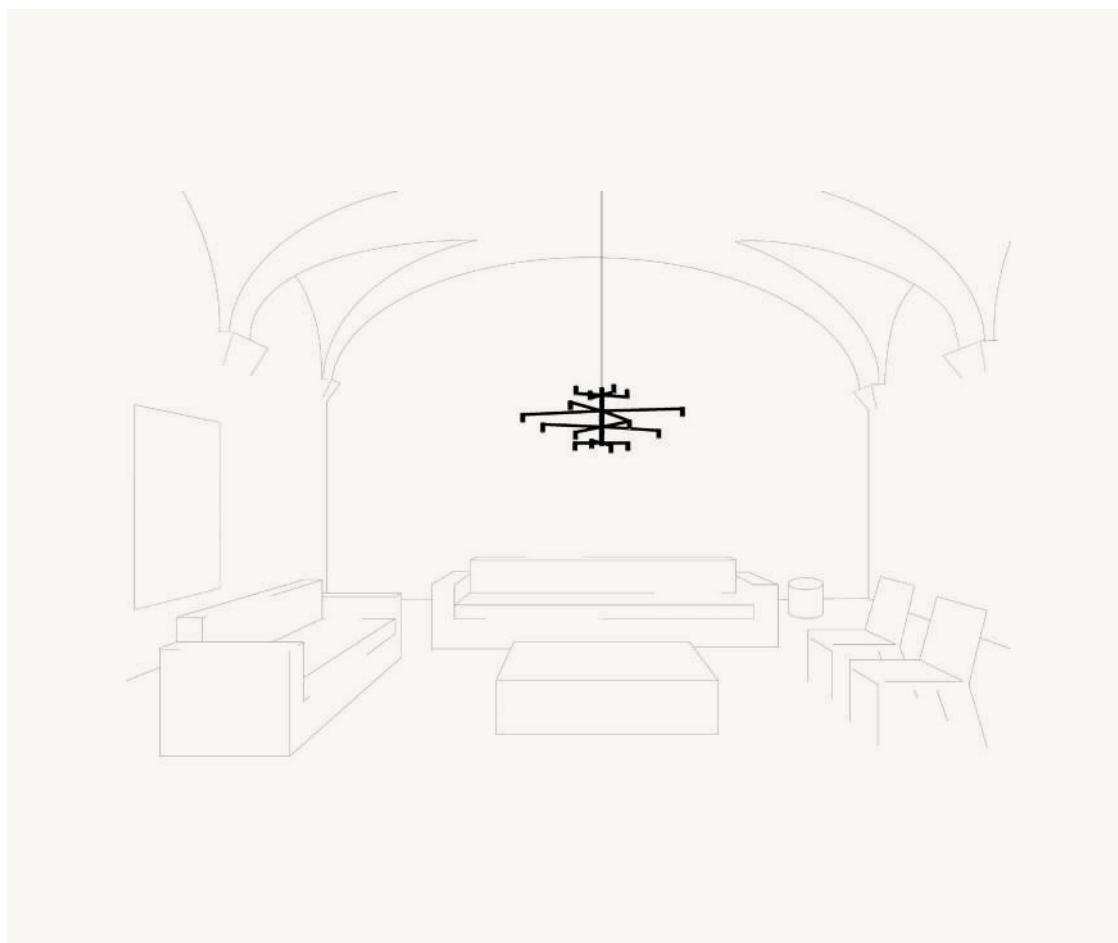



Lineal

PENDANT & CEILING - DOWNLIGHTING

5120

120 cm

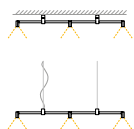
**5122**

180 cm

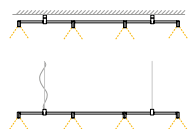
**5124**

270 cm

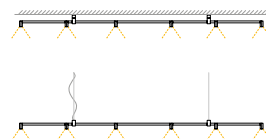

PENDANT - DOWNLIGHTING & UPLIGHTING

5150

120 cm

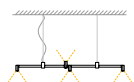
**5152**

180 cm

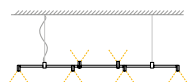
**5154**

270 cm

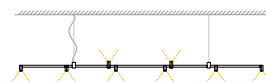

For pendants: max. height 300 cm

Rectangular

PENDANT & CEILING - DOWNLIGHTING

5130
120 x 60 cm

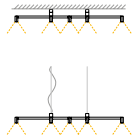

5132
180 x 60 cm

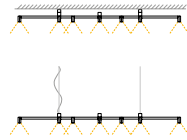

5134
270 x 60 cm

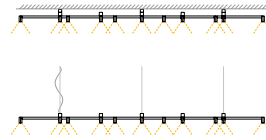

PENDANT - DOWNLIGHTING & UPLIGHTING

5160
120 x 60 cm

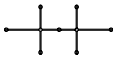
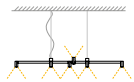

5162
180 x 60 cm

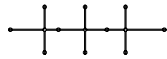
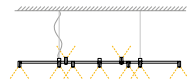

5164
270 x 60 cm

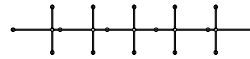
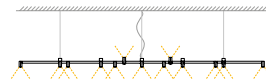

● 11 Black (NCS S 8500-N)

Body: Aluminum
Optic: PC- Polycarbonate
Canopy: Fe-Iron



LED Colour Temperature
2700 K; 3000 K; 3500 K; 4000 K
CRI>90

Control
Analog: 1-10V
Digital: DALI-2
Smart: Casambi



Electrical connection options



Remote

Built-in

Surface

Square

PENDANT & CEILING - DOWNLIGHTING

5140

120 x 120 cm

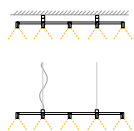
**5142**

180 x 180 cm

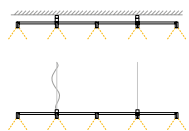
**5144**

270 x 270 cm

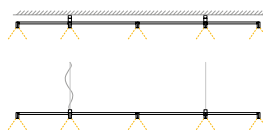
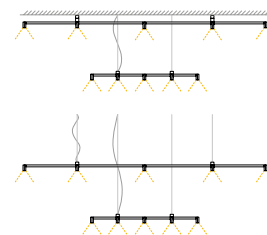
**5146**120 x 120 cm
270 x 270 cm

PENDANT - DOWNLIGHTING & UPLIGHTING

5170

120 x 120 cm

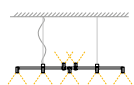
**5172**

180 x 180 cm

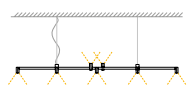
**5174**

270 x 270 cm

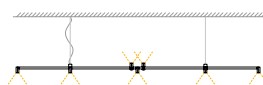
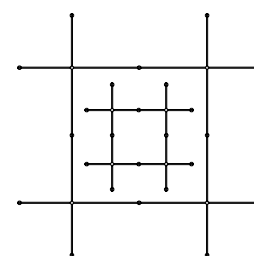
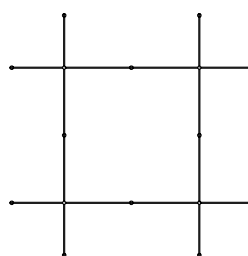
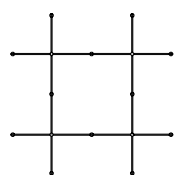
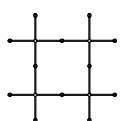
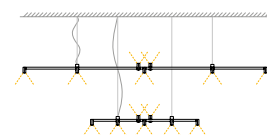
**5176**120 x 120 cm
270 x 270 cm

For pendants: max. height 300 cm

Volumetric

PENDANT - DOWNLIGHTING

5100

60 x 60 cm

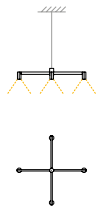

5102

90 x 40 cm

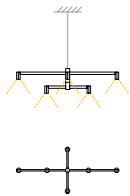

PENDANT - DOWNLIGHTING & UPLIGHTING

5104

120 x 120 cm

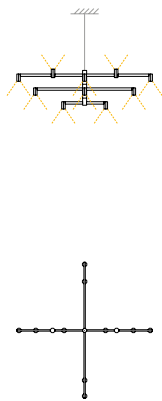

5106

270 x 270 cm

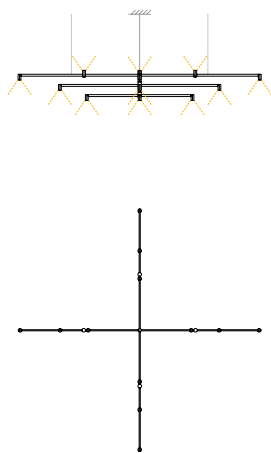

5110

Ø 120 cm

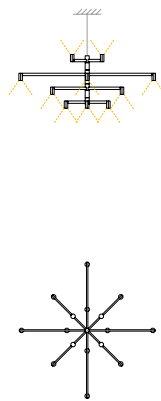

5112

Ø 180 cm

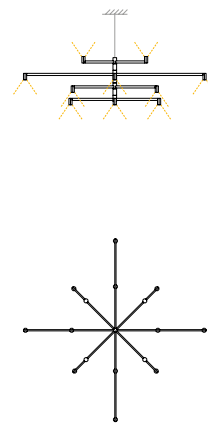

5114

Ø 270 cm

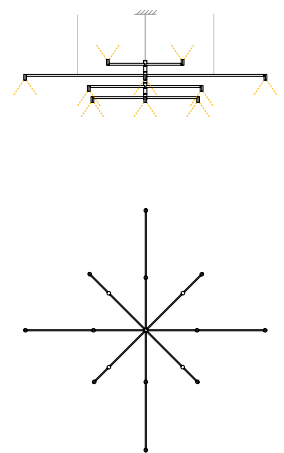

● 11 Black (NCS S 8500-N)

Body: Aluminum
Optic: PC- Polycarbonate
Canopy: Fe-Iron

LED Colour Temperature
2700 K; 3000 K; 3500 K; 4000 K
CRI>90

Control
Analog: 1-10V
Digital: DALI-2
Smart: Casambi

Electrical connection options

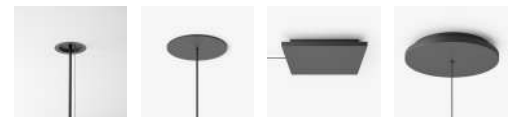

Remote

Built-in

Surface
Square

Surface
Volumetric

USE GUIDE

The Nexum collection is structured into four typologies: Lineal, Rectangular, Square and Volumetric.

Each configuration responds to a specific geometry and a defined method of light distribution, providing solutions adapted to different spatial scales and lighting requirements.

This user guide outlines the recommended application of each typology, supporting accurate specification according to the characteristics of the space and enabling the selection of the most appropriate illuminance level for each type of environment.

Nexum delivers even ground illumination from elevated heights, with precisely positioned spotlights and calibrated beam angles ensuring controlled, uniform light.

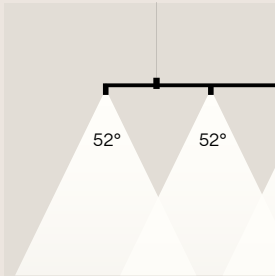

This diagram provides a general graphical reference on which the lighting calculations are based, considering two standard suspension heights (H1, H2). Depending on the typology, these heights may vary, as spatial integration and resulting illuminance levels differ according to the selected luminaire.



Lineal

The Lineal typology is ideal for longitudinal spaces where uniformity and precision are required.

Its distribution optimizes the lighting on continuous surfaces such as kitchen islands, workstations or corridors, ensuring visual comfort and a clean reading of the space.

It is particularly suitable for environments where functionality and light clarity are a priority, providing a balance between technical performance and discreet presence.

The **Downlighting & Uplighting** version enhances the perception of luminosity within the space. By illuminating the ceiling, it creates a more expansive ambient light with fewer light points.

*** H1 = 1 m**

Distance from the luminaire to a table or other surface to be illuminated

*** H2 = 3 m**

Distance from the luminaire to the floor

PENDANT & CEILING - DOWNLIGHTING

5120

120 x 3 cm

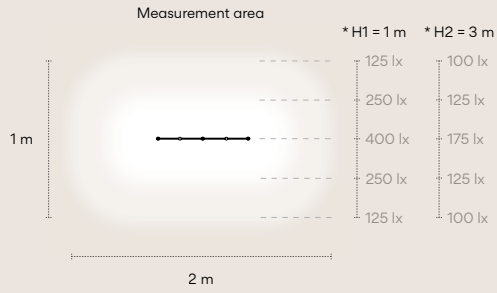

5150

120 x 3 cm

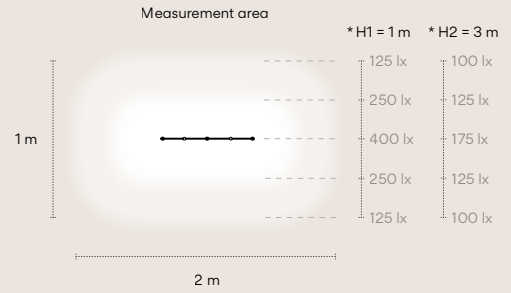

5122

180 x 3 cm

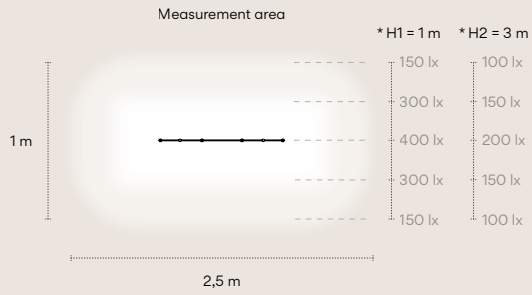

5152

180 x 3 cm

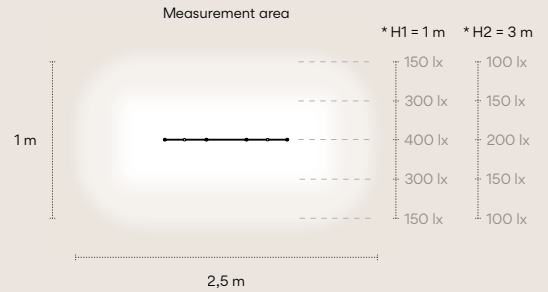

5124

270 x 3 cm

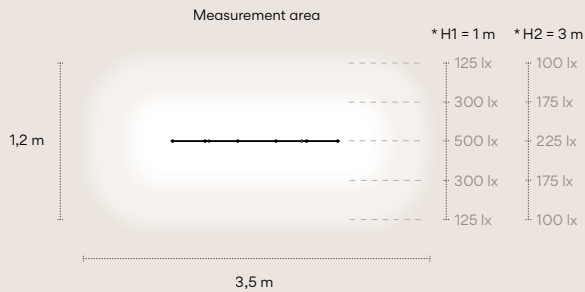

5154

270 x 3 cm

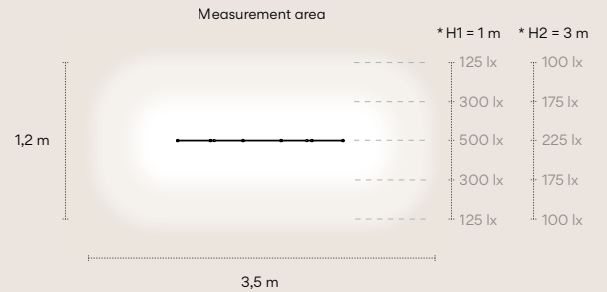



Rectangular

The Rectangular typology structures light within a defined perimeter, generating a sufficient volume of illumination over large and clearly delimited areas.

Suitable for large format tables, meeting/conference rooms requiring **500 lux**, as well as receptions or open workspaces with **300-500 lux** requirements.

Its configuration improves uniformity in wide rectangular planes and facilitates the fulfillment of average illuminance values, optimizing the relationship between number of light points and covered surface.

The **Downlighting & Uplighting** version enhances the overall luminosity of the space. Ideal for meeting rooms, it fosters an atmosphere of concentration and focus, while establishing a clear hierarchy of light that guides the user's gaze.

*** H1 = 1,5 m**

Distance from the luminaire to a table or other surface to be illuminated

*** H2 = 3 m**

Distance from the luminaire to the floor

PENDANT & CEILING - DOWNLIGHTING

5130

120 x 60 cm

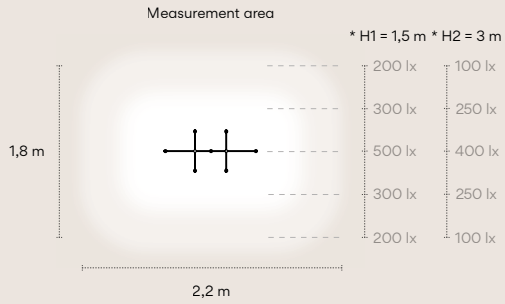

5132

180 x 60 cm

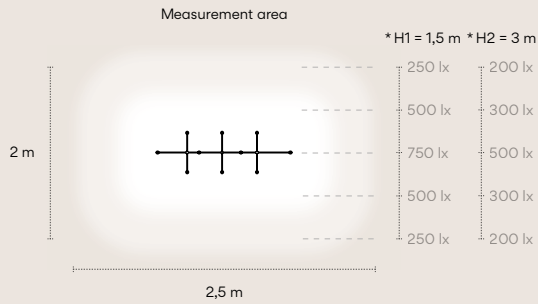

5134

270 x 60 cm

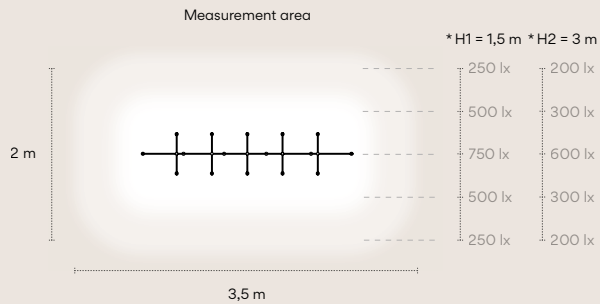

PENDANT - DOWNLIGHTING & UPLIGHTING

5160

120 x 60 cm

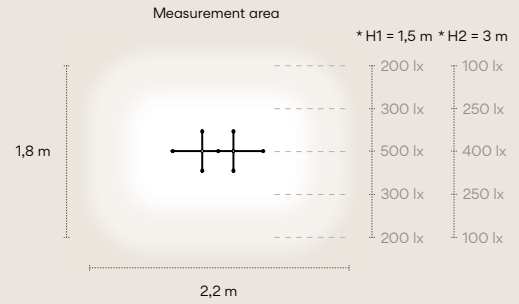

5162

180 x 60 cm

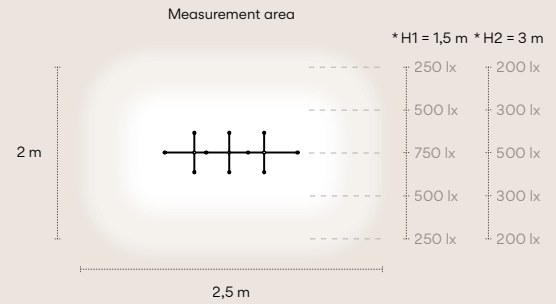

5164

270 x 60 cm

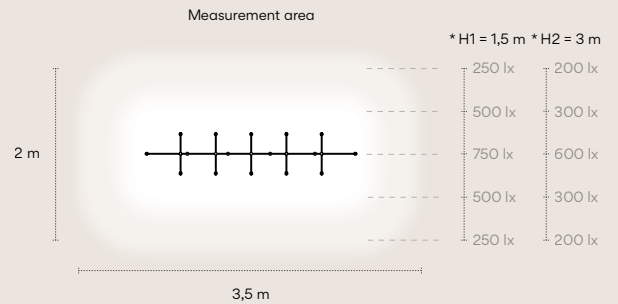

Square

The Square typology is especially suitable for lounge areas, lobbies or medium-sized meeting rooms, where you want to prioritize a specific area without overloading the environment.

It allows reaching **300-500 lux** in meeting rooms, **300 lux** in lounge or hospitality areas for occasional work, and lower levels **200 lux** in transition or waiting zones.

Its configuration favors a balanced uniformity on the useful plane and reduces excessive contrasts, ensuring visual comfort and spatial consistency in medium-scale environments.

By illuminating the ceiling with the **Downlighting & Uplighting** luminaires, a greater sense of luminosity is achieved throughout the space, reducing the number of light points required. For large areas such as lobbies or spacious rooms, it offers an effective solution for creating a well-balanced lighting environment.

PENDANT & CEILING - DOWNLIGHTING

5140

120 x 120 cm

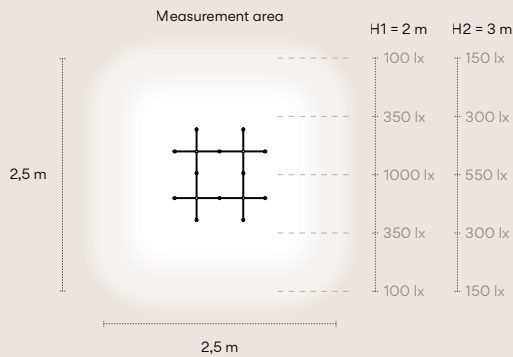

5142

180 x 180 cm

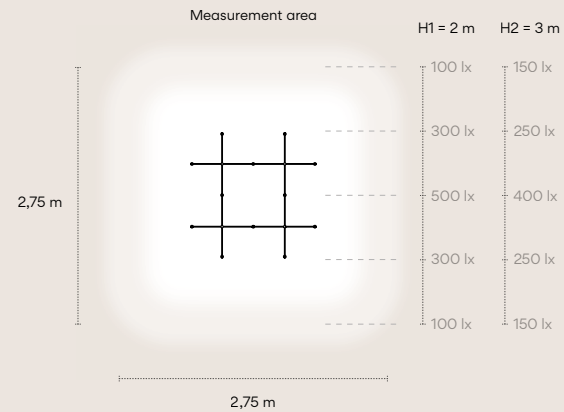

5144

270 x 270 cm

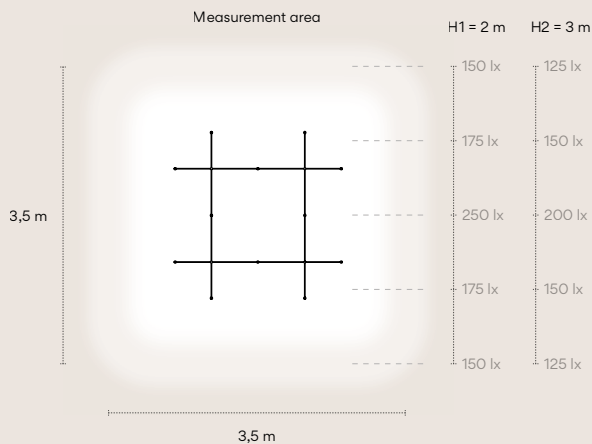

5146

270 x 270 / 120 x 120 cm

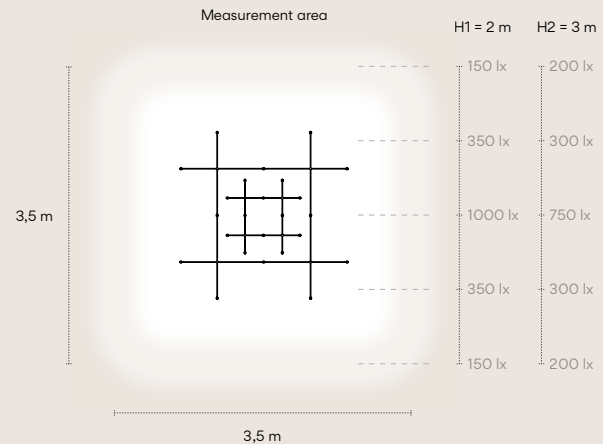

PENDANT - DOWNLIGHTING & UPLIGHTING

5170

120 x 120 cm

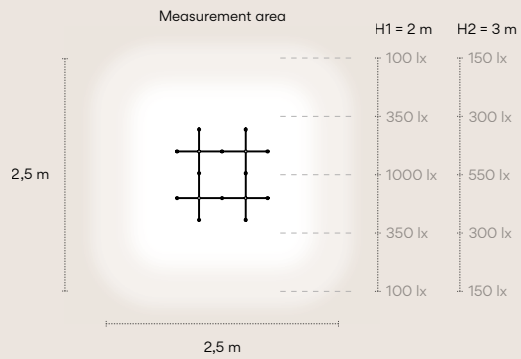

5172

180 x 180 cm

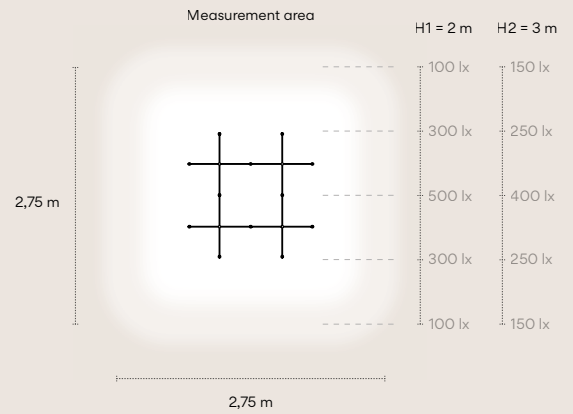

5174

270 x 270 cm

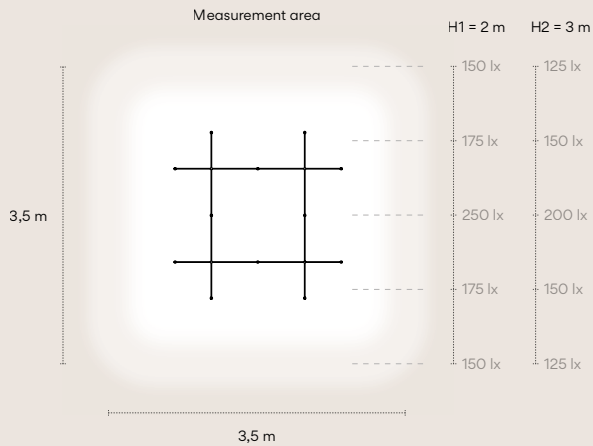

5176

270 x 270 / 120 x 120 cm

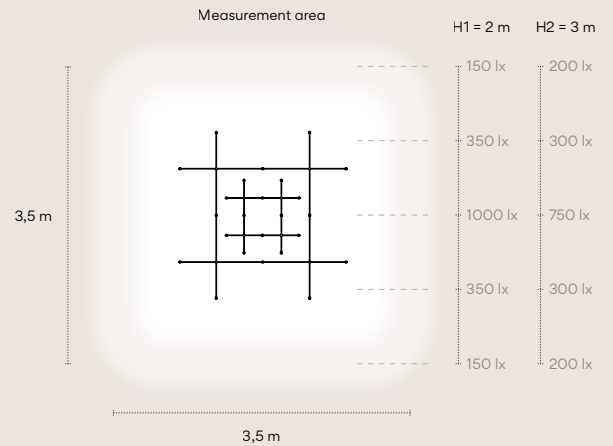

Volumetric

The Volumetric typology incorporates a three-dimensional configuration that multiplies the emission points, allowing to extend the light coverage in larger spaces or with significant heights.

Pendant Downlighting references 5100 and 5102, of more contained dimensions, offer a suitable luminous flux to reach appropriate levels of illuminance in auxiliary tables, coffee tables or workstations of reduced scale, ensuring uniformity and visual comfort.

Downlighting & Uplighting references 5104, 5106, 5110, 5112 and 5114 are designed for larger applications, such as double heights, lobbies, restaurants or showrooms, where a greater coverage area and spatial presence is required.

Its configuration optimizes the distribution of the luminous flux in wide spaces, maintaining a light and architectural structural reading, and facilitating compliance with the lighting and visual comfort requirements specific to contract and representative environments.

*** H1 = 1,5 m**

Distance from the luminaire to a table or other surface to be illuminated

*** H2 = 3 m**

Distance from the luminaire to the floor

PENDANT - DOWNLIGHTING

5100

60 x 60 cm

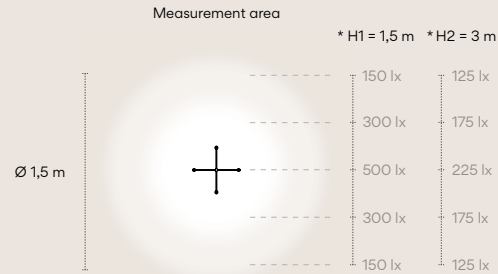

5102

90 x 40 cm

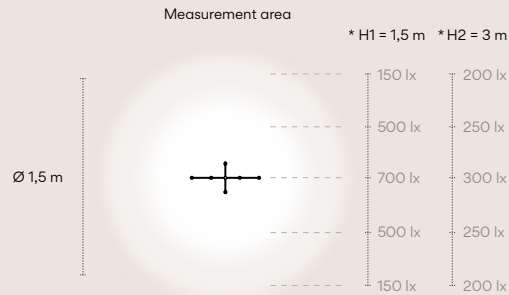

PENDANT - DOWNLIGHTING & UPLIGHTING

5104

120 x 120 cm

Measurement area

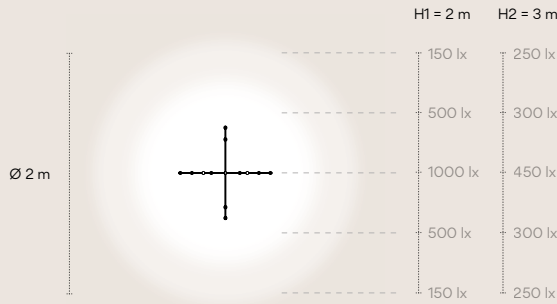

5110

Ø 120 cm

Measurement area

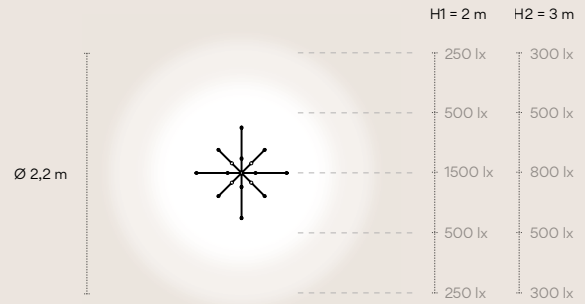

5106

270 x 270 cm

Measurement area

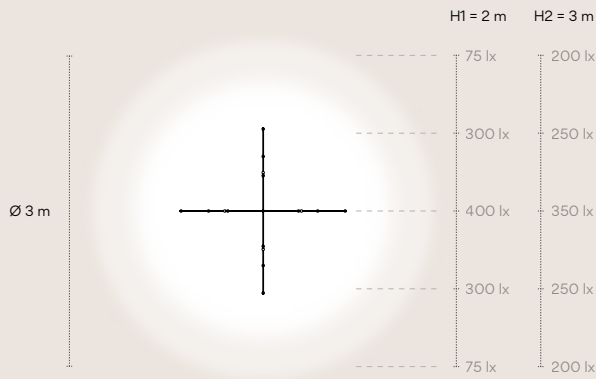

5112

Ø 180 cm

Measurement area

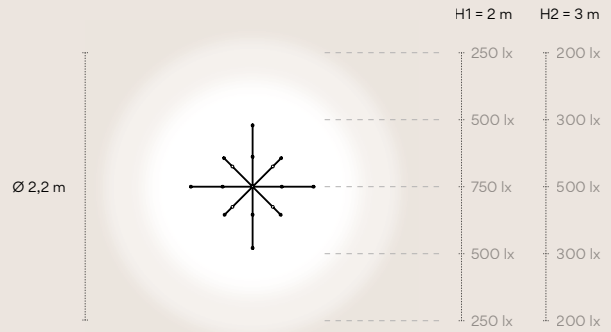

5114

Ø 270 cm

Measurement area

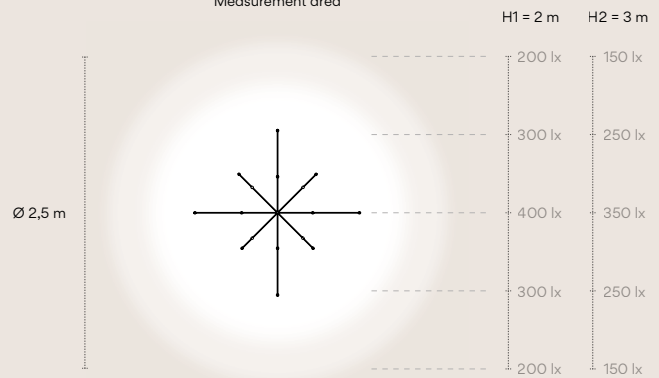





Pro



Design by Holscher Design.

The spotlight concept is reimagined with Pro. Three different diameters offer greater compositional freedom, combining various levels of high-performance luminous flux while ensuring visual harmony between luminaires of different sizes within a project. Pro shapes spaces, moods and atmospheres through dynamic light effects, expressed in a sculptural and refined geometry that integrates seamlessly into any interior project.

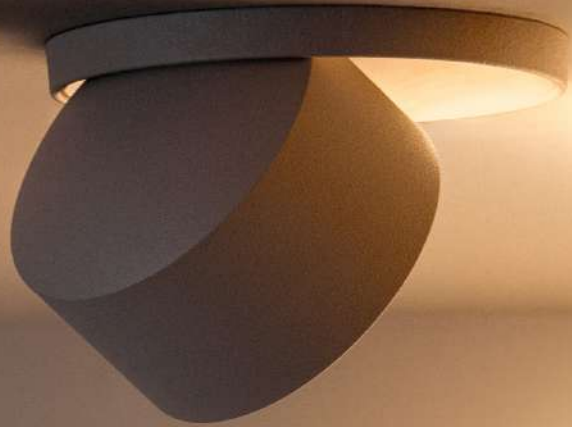

Pro delivers precise accent lighting across three beam options—narrow, medium and wide—defined by the selected model. With outputs of up to 2.800 lumens, its high-performance optics ensure controlled intensity, visual comfort and excellent colour rendering for demanding architectural applications.

Luminous flux 800 - 2.800 lm

“The foundation of this series is a fusion of minimalism and functionality. We aimed to design a sculptural spotlight where two geometric forms touch, creating an intriguing visual dynamic. The movement of two spheres was inspired by the path of the sun on the hemisphere.”

Holscher Design

For ceiling installation, Pro adapts gracefully to a range of configurations: trim, trimless, surface-mounted, or track-mounted—visible or concealed. Its moving cylinder combines rotation and tilt, directing light with precision, from focused to wide beams. Minimalist and sculptural, the luminaire fades into the background, letting light take centre stage and enhancing the expressive potential of the space.





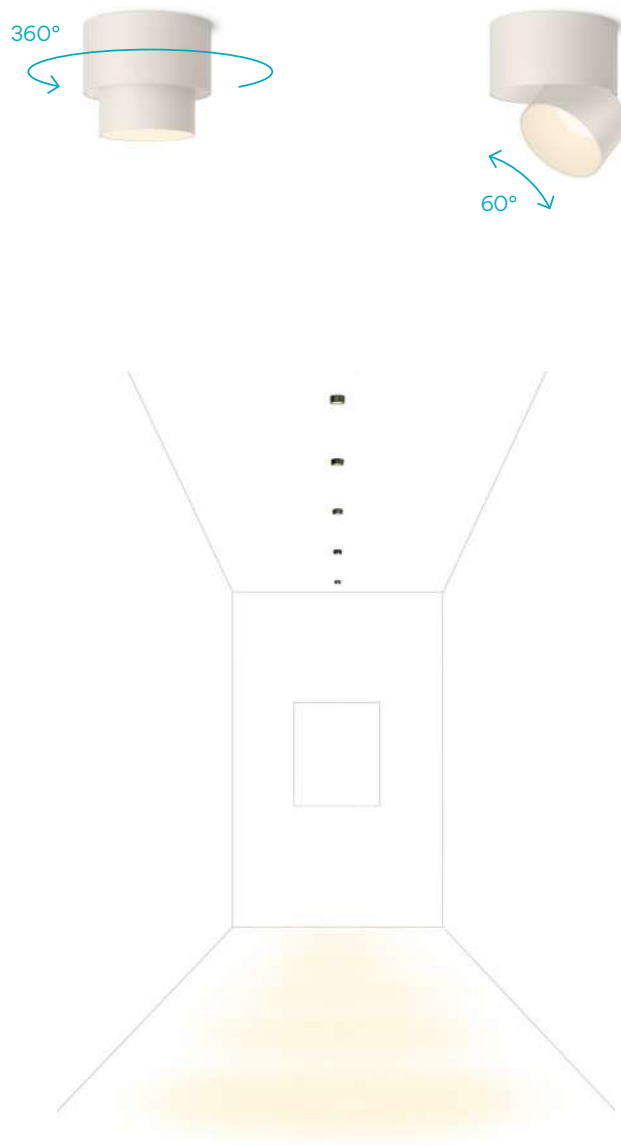

Pro combines downlight and spotlight functions in a single system thanks to its dual rotation. In its fixed position, it delivers controlled, uniform downward light, while the adjustable head can be rotated and angled to enable precise directional illumination, highlighting architectural elements and specific areas of the space.







Pro adopts a more adaptable and flexible expression when installed on streamlined track systems, either surface-mounted or built-in. The track allows the luminaires to be freely repositioned along the line, while their adjustable design enables precise positioning and orientation, expanding architectural integration possibilities while preserving dynamic lighting and variable rotation.



Pro stand-alone captures the core technical aspects of the collection in a self-sufficient format that does not require architectural integration or support. Whether free-standing or bolt-down, its quiet, sculptural presence integrates discreetly into the environment, while its orientable design allows light to be directed upward from the ground to illuminate large vertical surfaces, transforming the space with a unique, luminous experience.





Direct / Indirect accent lighting

With direct accent lighting, we focus all attention on the displayed object, creating a more dramatic and theatrical effect.

With indirect accent lighting, on the other hand, the ambient space is illuminated in order to present the product in a softer, more visually calm way.



The same product takes on different hierarchies and functions depending on the layout and the role of each element within the space. The table at the back and the central plinths are illuminated with a downlight positioned directly above, creating a clear visual hierarchy with a theatrical tone. The two Pro luminaires on the sides, by contrast, act as spotlights to provide general illumination for the products displayed along the walls. With this lighting proposal, the visitor's spatial and visual journey is clearly defined.















Pro wall extends the collection's lighting possibilities beyond the ceiling, introducing directed light projected from the wall to illuminate both ceilings and architectural elements. This alternative point of emission opens up new lighting angles, allowing surfaces and spatial features to be highlighted with precision and control.





Accent Spotlight

Ceiling

CEILING TRIMLESS

CEILING TRIM

CEILING SURFACE

Ø 7 cm



Narrow

Medium

Wide

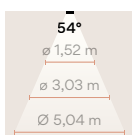
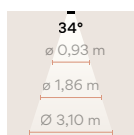
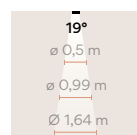

H = 1,5 m

H = 3 m

H = 5 m

ø 0,5 m 1408 lx
ø 0,99 m 352 lx
ø 1,64 m 127 lx

ø 0,93 m 516 lx
ø 1,86 m 129 lx
ø 3,10 m 46 lx

ø 1,52 m 272 lx
ø 3,03 m 68 lx
ø 5,04 m 24 lx

7030 Narrow
7032 Medium
7034 Wide

7030 Narrow
7032 Medium
7034 Wide

7000 Narrow
7002 Medium
7004 Wide

Ø 9 cm



Narrow

Medium

Wide

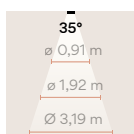
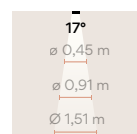

H = 1,5 m

H = 3 m

H = 5 m

ø 0,45 m 4156 lx
ø 0,91 m 1039 lx
ø 1,51 m 374 lx

ø 0,91 m 1244 lx
ø 1,92 m 311 lx
ø 3,19 m 112 lx

ø 1,65 m 612 lx
ø 3,30 m 153 lx
ø 5,51 m 55 lx

7040 Narrow
7042 Medium
7044 Wide

7040 Narrow
7042 Medium
7044 Wide

7010 Narrow
7012 Medium
7014 Wide

Ø 12 cm



Narrow

Medium

Wide

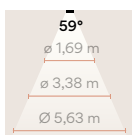
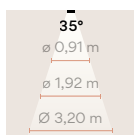
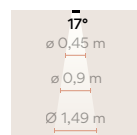

H = 1,5 m

H = 3 m

H = 5 m

ø 0,45 m 5652 lx
ø 0,9 m 1413 lx
ø 1,49 m 509 lx

ø 0,91 m 1660 lx
ø 1,92 m 415 lx
ø 3,20 m 150 lx

ø 1,69 m 800 lx
ø 3,38 m 200 lx
ø 5,63 m 72 lx

7050 Narrow
7052 Medium
7054 Wide

7050 Narrow
7052 Medium
7054 Wide

7020 Narrow
7022 Medium
7024 Wide

Track-mounted

Stand-alone

TRACK SURFACE TRACK TRIMLESS



7060 Narrow
7062 Medium
7064 Wide

7060 Narrow
7062 Medium
7064 Wide



7070 Narrow
7072 Medium
7074 Wide

7070 Narrow
7072 Medium
7074 Wide



PLUG
7092 Medium

BOLT-DOWN
7110 Narrow
7112 Medium
7114 Wide



7080 Narrow
7082 Medium
7084 Wide

7080 Narrow
7082 Medium
7084 Wide



PLUG
7102 Medium

BOLT-DOWN
7120 Narrow
7122 Medium
7124 Wide

- 11 Black (NCS S 8500-N)
- 23 Warm White (NCS S 0502-Y50R)
- 24 Beige M1 (NCS S 2005-Y50R)

Optic: PC- Polycarbonate
Body: Aluminum

LED Colour Temperature

CRI>90

Ø 7 cm

2700K - 1098 lm
3000K - 1148 lm
3500K - 1189 lm
4000K - 1214 lm
Tunable White
(1800K - 4000K) - 308-504 lm

Ø 9 cm

2700K - 1961 lm
3000K - 2050 lm
3500K - 2124 lm
4000K - 2300 lm
Tunable White
(1800K - 4000K) - 571-895 lm

Ø 12 cm

2700K - 2676 lm
3000K - 2798 lm
3500K - 2899 lm
4000K - 2960 lm
Tunable White
(1800K - 4000K) - 735-1152 lm

Control

Analog: On/Off; Push
Digital: DALI-2
Smart: Casambi

Electrical connection

Ceiling models:

- Surface
- Built-in
- Remote
- To track

Stand-alone models:

- Plug
- Bolt-down

Ceiling Tracks

The bar amplifies the possibilities for shaping a space by conducting electricity and transporting light to wherever it is needed.

● 11 Black (NCS S 8500-N)

Track: Aluminum

48 V



Electrical connection options

A range of connection accessories and additional complementary accessories is available. For more information, please visit vibia.com

TRACK SURFACE

T001 100 cm
T002 200 cm
T003 300 cm

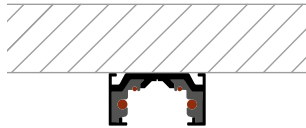

TRACK TRIMLESS

T011 100 cm
T012 200 cm
T013 300 cm



Surface driver



Remote driver



Remote driver

100 cm

200 cm

300 cm



Las estatuas representan uno de los modelos más típicos de la periodización clásica antes del descubrimiento de Roma. Esta calificación se basó principalmente en la región de Etruria, lo que hoy conocemos como Toscana, Lazio y Umbria, alcanzando su máximo esplendor entre los siglos sexto y cuarto antes de nuestra era. Aunque su origen se debe esencialmente a la cultura etrusca, los griegos y romanos, lo cierto es que desarrollaron una cultura sofisticada, urbana y profundamente religiosa que sirvió como el punto fundamental entre el mundo griego y el romano.

A diferencia de otros períodos de la época, los etruscos construyeron por una estructura social donde las mujeres disfrutaban de una libertad y un estatus excepcionales. Podían asistir a banquetes, participar en la vida pública y trabajar en propios negocios, algo que era prohibido a sus vecinos griegos y romanos. Desarrollaron de la ingeniería, expertos en el diseño de puentes y en la construcción de canales de riego; controlaron el comercio con sus aliados y sus enemigos, y fueron el núcleo de una cultura que dio origen a una civilización única.

La influencia etrusca en la cultura romana se puede apreciar a través de la arquitectura, la religión y la lengua. Los etruscos, que vivieron en el centro de la península italiana, fueron el puente entre el mundo griego y el romano. Su cultura, que se basó en la religión y la política, sirvió como un modelo para los romanos, quienes adoptaron muchos de sus valores y tradiciones.

En el arte, los etruscos desarrollaron una tradición única que combinó elementos griegos y romanos. Su escultura, especialmente en el trabajo de los bronce, muestra una habilidad excepcional en la creación de figuras humanas y animales. El famoso bronce de la mujer de Capua es un ejemplo de esta tradición. Los etruscos también fueron pioneros en el uso del mármol para la escultura, lo que permitió la creación de obras más grandes y detalladas. Su legado artístico perduró en el mundo romano y en el arte occidental.



Escultura romana

Una de las obras más importantes de la escultura romana es el busto de Nerón, que muestra al emperador con una expresión serena y una postura erguida. Este busto es un ejemplo de la habilidad romana para crear esculturas que reflejan el poder y la autoridad de sus gobernantes. El uso del mármol permitió a los romanos crear obras más grandes y detalladas que las griegas, lo que les permitió representar a sus gobernantes de una manera más realista y humana.

Shaping Atmospheres

Vibia offers a range of general, accent, and downlight luminaires with tunable white options. By combining these zenithal fixtures with diffused and indirect lighting effects from Vibia's portfolio, it is possible to create the ideal ambience for any occasion or purpose.



Tunable White (1800K - 4000K)

A tunable white lighting option allows for comprehensive temperature regulation depending on the atmosphere of each scene.

Static White 2700K; 3000K; 3500K; 4000K

You can select the static white option that best fits the desired ambience.

Static White

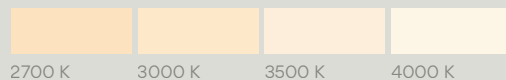

Tunable White

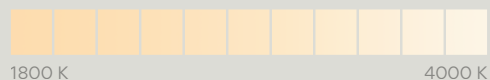

Contact Vibia Support Service at vibia.com

for assistance or recommendations when designing lighting atmospheres, or if you require support with control systems.

Additional lighting effects to design atmospheres of wellbeing (coming soon)

Colour Mood Projector Wide Flow Washer

Vibia's approach to coloured light encourages the use of colour and gradients to create a wide range of atmospheres, from natural and subtle to more expressive effects. Natural light is never mono-tonal; infinite gradients add depth and nuance to space.

Graphic Light Gobo Projector

Gobos introduce an abstract visual language that suggests rather than explicitly describes. From subtle patterns to more complex graphic compositions, they create scenes that evoke emotion and add narrative depth. The projected light becomes texture and story, enriching the atmosphere without imposing a material presence.







ACKNOWLEDGEMENTS

Photography: Mariela Apollonio
Architecture: Ramón Esteve Estudio
(Page 8, 9, 99)

Kettal
(Page 12, 21 and 27)

Photography: Mariela Apollonio
Project: Estudio Correo Viejo@estudiocorreoviejo
(Page 13 and 19)

Teixidors
www.teixidors.com
(Page 15, 17, 23, 50 and 69)

Carl Hansen & Søn
(Page 20, 49, 69 and 109)

Yoyo Balagué
yoyobalague.com
@yoyobabcn
(Page 37, 46 and 47)

Photography: Mariela Apollonio
Architecture: R21@r21arkitekter
(Page 38 and 39)

Photography: Mariela Apollonio
Project: Estudio Lucus@studio_lucus
(Page 52, 108)

Louisa, Vincent Van Duysen available at MINIM
Barcelona Via Augusta, 185
(Page 52)

Project: Espacio Home Design
(Page 53, 72 and 101)

Sita Murt
(Page 63)

Photography: Mariela Apollonio
Architecture: Juan Grau Fernández Arquitectura
(Page 65)

Photography: Mariela Apollonio
Architecture: Lecoc Arquitectura
(Page 79)

Vibia Lighting, S.L.U.

Spain & Portugal T. +34 934 796 970
International T. +34 934 796 971
hello@vibia.com
www.vibia.com

vibia.com